

ShadeSense Alternative Wood Blinds

WHY CHOOSE SHADESENSE?

ShadeSense Alternative Wood Blinds are a cost-effective alternative to wood and composite wood blinds. Constructed from engineered polymer, ShadeSense blinds are durable, easy to clean, and simple to maintain.

Ideal for large-scale projects, explore 20 colorways that will elevate any space.

KEY FEATURES

2" and 2 1/2" Flat Slats of Engineered
Polymer Material

Safe for Kids and Pets

Cordless Lift with Balanced Spring
Motor for Enhanced Safety

Increased Privacy and Light Control

Easy to Mount

Backed by our Lifetime Guarantee

ShadeSense Alternative Wood Blinds

| Color Options

All colors shown are available in the 2" slat.

* denotes colors available in the 2-1/2" slat.

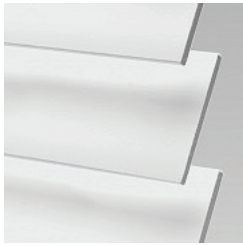

377 & 477* White



378 & 478* Extra White

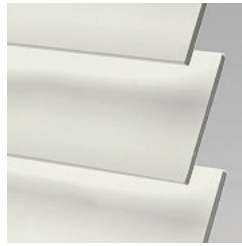

379 & 479* Pure White

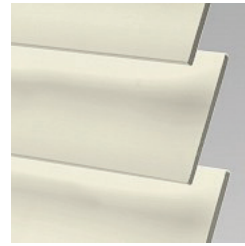

380 & 480* Roman White

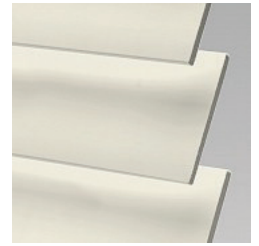

381 & 481* Incredible White

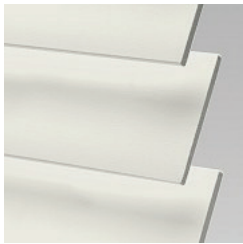

376 & 476* Antique White

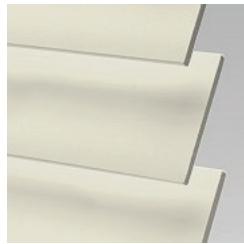

374 & 474* Ivory



375 & 475* Alabaster

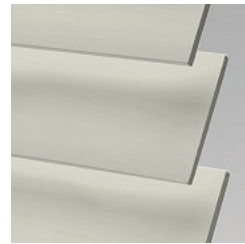

902 & 502* Pewter

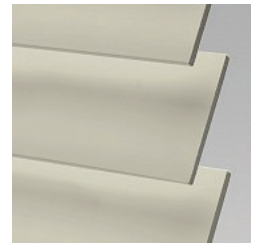

903 & 503* Warm Gray

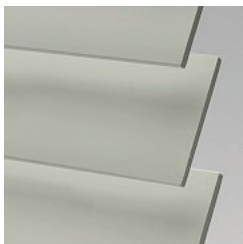

905 & 505* Steel

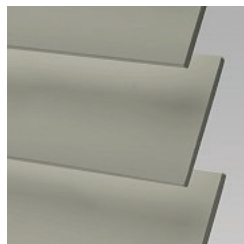

901 & 501* Light Gray

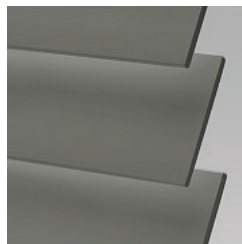

904 & 504* Dark Gray



T377 White Textured



T379 Pure White Textured



T376 Antique White Textured



T902 Pewter Textured



T903 Warm Gray Textured

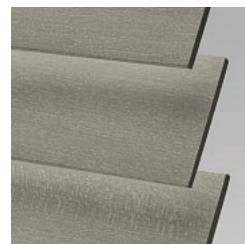

362 Gray Wash

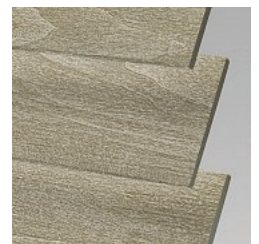

361 Sea Mist

ShadeSense Alternative Wood Blinds

| ShadeSense Alternative Wood Blinds Cordless

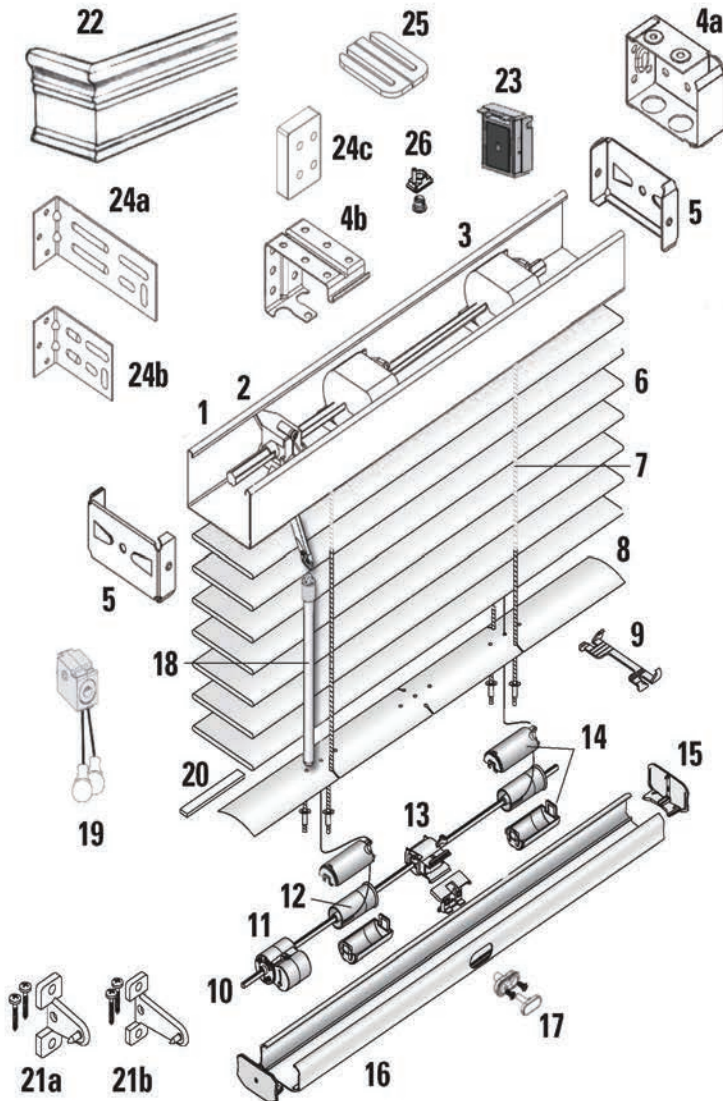

PRODUCT COMPONENTS – CORDLESS LIFT & LOCK™

STANDARD PARTS

1. Slim Design Headrail
2. Wand Tilter
3. Tape Drum
- 4a. Installation Bracket
- 4b. Center Support Bracket
5. End Lock End Stiffener
6. Faux Wood Slats
7. Lift Cords
8. 2" Aluminum Slat
9. 2" Top Slat Clip
10. "V" Tiltrod
11. Lift & Lock Motor
12. Lift 7 Lock Spool
13. 2" Lock Assembly
14. Support and Cover Set
15. Lift & Lock Bottomrail End Cap
16. Lift & Lock Bottomrail
17. Lift & Lock Button Screw
18. Wand Tilt
19. Cord Tilter
20. Foam Tape

OPTIONAL PARTS

- 21a. Lift & Lock Hold Down Brackets, Sill
- 21b. Lift & Lock Hold Down Brackets, Jamb
22. Valance
23. Magnetic Valance Clip
- 24a. Long Extension Bracket
- 24b. Short Extension Bracket
- 24c. Spacer Block
25. Bracket Shim
26. Cord Screw Adjuster