

Installation • Operation • Care



**Duette® Honeycomb  
Shades**  
PowerView® Gen 3  
Automation



# CONTENTS

---

<b>GETTING STARTED .....</b>	<b>1</b>
Product View.....	1
Tools and Fasteners Needed .....	2
<b>INSTALLATION .....</b>	<b>3</b>
Installation Overview.....	3
STEP 1: Mount the Installation Brackets.....	3
Mount the Installation Brackets — Inside Mount.....	4
Mount the Installation Brackets — Outside Mount .....	7
Mount the Installation Brackets — End Mount.....	9
STEP 2: Mount the Battery Wand (If Applicable).....	10
STEP 3: Install the Shade.....	12
STEP 4: Connect the Power Source .....	13
Testing the Shade .....	19
Attach Magnetic Hold-Down Brackets (Optional).....	20
<b>OPERATION .....</b>	<b>24</b>
Operating the PowerView® App and Gen 3 Remote.....	24
Resetting the Shade .....	28
Level the Rail(s) .....	29
<b>TROUBLESHOOTING .....</b>	<b>30</b>
<b>CARE.....</b>	<b>36</b>
Removing the Shade.....	36
Cleaning Procedures .....	36
<b>DECLARATIONS.....</b>	<b>38</b>
<b>CHILD SAFETY .....</b>	<b>39</b>
<b>WARRANTY .....</b>	<b>40</b>

---

## Questions?

Contact Hunter Douglas Consumer Support at [help.hunterdouglas.com](https://help.hunterdouglas.com).

**Product View**

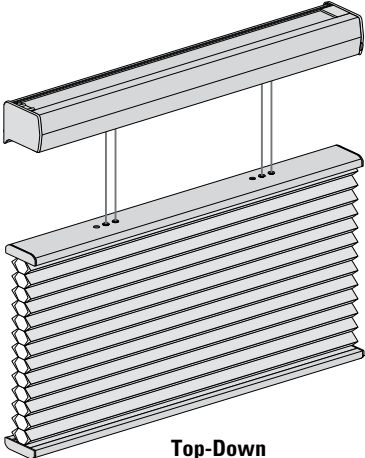
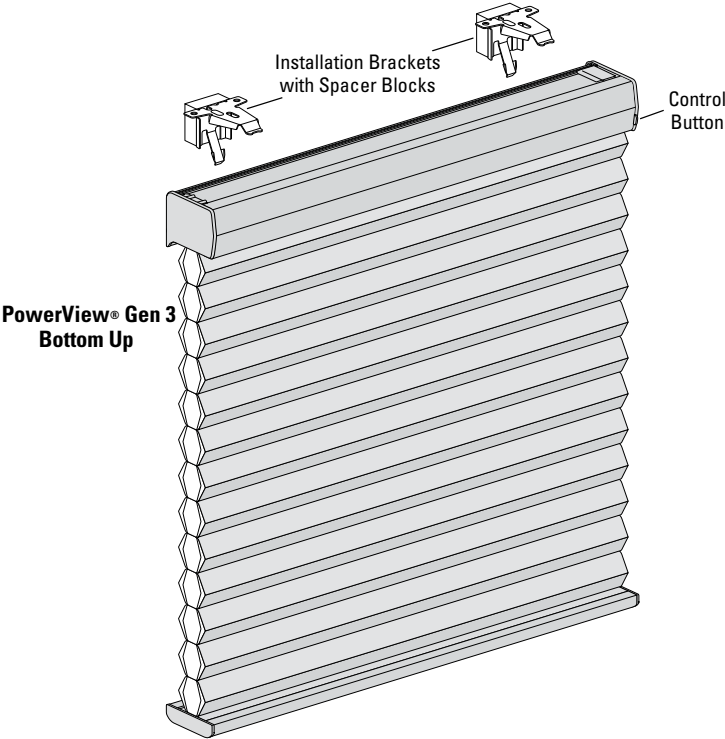

## GETTING STARTED

---

Thank you for purchasing Hunter Douglas Duette® Honeycomb Shades with PowerView® Gen 3 Automation. With proper installation, operation, and care, your new shades will provide years of beauty and performance.

Please thoroughly review this instruction booklet and the enclosed packing list before beginning the installation.

### Tools and Fasteners Needed

- ¼" Hex, Flat blade, and Phillips screwdrivers
- Level (laser level is recommended)
- Measuring tape and pencil
- Power drill, ⅜" drill bit, and ¼" hex driver

In addition, you will need fasteners designed to work with your specific mounting surface(s).

- **#6 Hex Head Screws (Provided).** Two 1½" screws are provided per installation bracket.
- **Longer #6 Hex Head Screws (Not Provided).** If using spacer blocks, use #6 screws long enough for a secure attachment.
- **#6 Flat Head Screws (Provided).** If end mounting the shade, use two 1½" screws per installation bracket.
- **Speed Nuts and Screws (Provided).** Extension brackets come with speed nuts and screws.
- **Drywall Anchor (Not Provided).** Use drywall anchors when mounting into drywall.



**#6 x 1½"**  
**Hex Head Screw**  
(Provided)



**Longer #6 Hex Head Screw**  
**for Use**  
**with Spacer Blocks**  
(Not Provided)



**#6 Flat Head Screw**  
**for Use**  
**with End Mounts**  
(Provided)



**Speed Nut and Screw**  
(Two Provided  
with Each  
Extension Bracket)

## Installation Overview

To install your shade, you will need to perform the following four steps:

**STEP 1:** Mount the Installation Brackets

**STEP 2:** Mount the Battery Wand, If Applicable

**STEP 3:** Install the Shade

**STEP 4:** Connect the Power Source

### STEP 1: Mount the Installation Brackets

■ Your order will include the correct number of installation brackets for your shade width, as shown in the table.

- There are two sizes of installation brackets, one for  $\frac{3}{8}$ " and  $\frac{3}{4}$ " pleat sizes and a larger one for the  $1\frac{1}{4}$ " pleat size.
- For end mounts, two brackets are used up to the maximum width of 72".

Shade Width	Brackets Required
12" – 36"	2
$36\frac{1}{8}$ " – 72"	3
$72\frac{1}{8}$ " – 108"	4
$108\frac{1}{8}$ " – 144"	5
$144\frac{1}{8}$ " – 174"	6

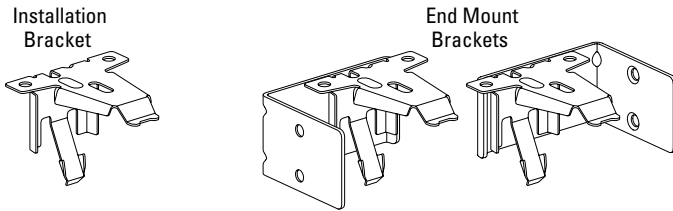

**IMPORTANT:** A  $\frac{1}{2}$ " spacer block is required for shades using an attached battery wand; two  $\frac{1}{2}$ " spacer blocks are required for shades using a headrail-mounted rechargeable battery wand. The spacer blocks are pre-attached to the back of the installation bracket.

■ Should the spacer block become detached, reattach it.

- Insert the legs of the installation bracket into the tabs on the spacer block.
- Rotate the installation bracket back, as shown, to snap it in place.

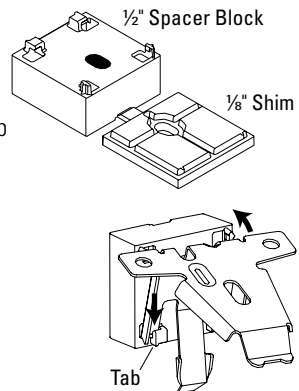

# INSTALLATION

## Mounting Types and Window Terminology

If the installation brackets are mounted correctly, the rest of the installation process follows easily. To prepare for this important first step, review the mounting types and basic window terminology illustrated below.

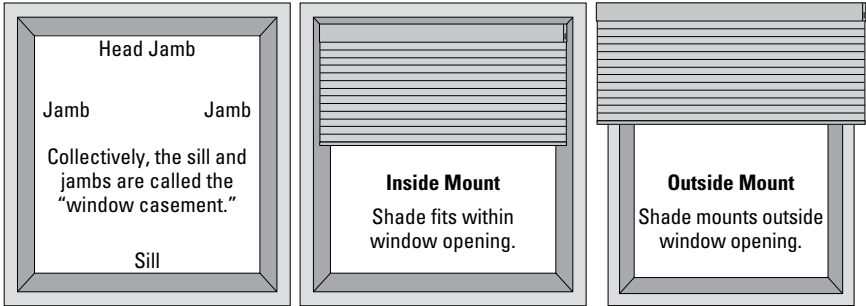

- Refer to the appropriate page below based on your order:
  - **Inside Mount** — below
  - **Outside Mount** — Page 7
  - **End Mount** — Page 9

## Mount the Installation Brackets — Inside Mount

- Mark 2" in from each jamb for bracket location.
  - If more than two installation brackets came with your order, space additional bracket(s) evenly between the two end brackets and mark their location. **Allow a minimum of 15" between the brackets on the right-side motor end for the battery wand/rechargeable battery wand.** Mount into wood whenever possible.

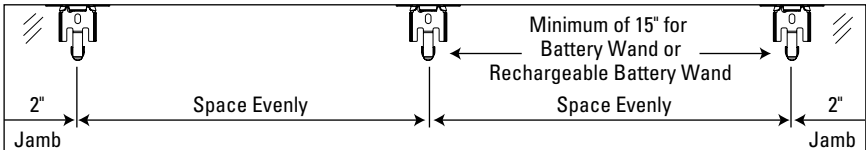

- Center the brackets on your marks, then mark each of the screw holes.
  - Mounting depths vary depending on the fabric pleat size. See the following chart for minimum and fully recessed depth requirements (measured from the front of the sill to the back of the installation bracket).
  - Mark both winged screw holes with shallow mounting depths.
  - Mark the center screw hole when depth permits. The center hole requires 1½".

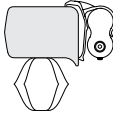
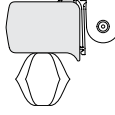
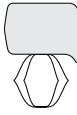
Mounting Depth Requirements						
Pleat Size:	 Battery Wand High Mount Bracket (Standard)		 Headrail- Mounted Rechargeable Battery Wand (Optional)		 Satellite Battery Pack/ Rechargeable Battery Wand, C-Size Battery Wand, 18V DC Power Supply, 16 Shade DC Power Supply	
	3/8", 3/4"	1 1/4"	3/8", 3/4"	1 1/4"	3/8", 3/4"	1 1/4"
Minimum casement depth: <b>Inside Mount</b>	1"	1"	1 1/4"	1 1/4"	1/2"	1/2"
Minimum casement depth: <b>End Mount</b>	1 3/4"	1 3/4"	2"	2"	1 1/4"	1 1/4"
Minimum casement depth: <b>Flush Mount</b>	2 3/4"	3 1/2"	3 1/8"	3 3/4"	2 1/4"	3 3/8"
Minimum mounting surface height: <b>Outside Mount</b>	1 1/4"	1 1/4"	1 1/4"	1 1/4"	1 1/4"	1 1/4"

**NOTE:** When using a Solar Charger, consider the charger's total thickness/depth and clearance from window covering, when mounting directly to the glass. For additional considerations on Solar Charger clearance, see the Getting Started and Mounting sections of the [Solar Charger Installation Guide](#).

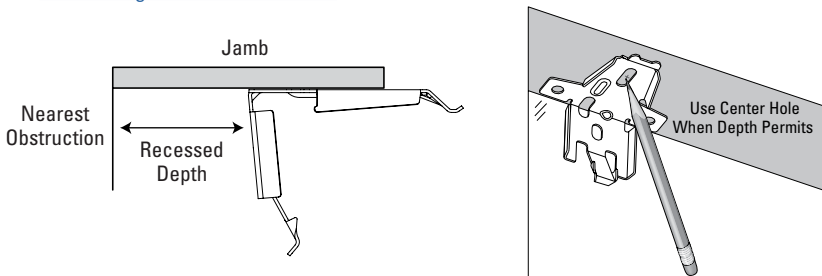

## INSTALLATION

---

- Drill the screw holes using a  $\frac{3}{32}$ " drill bit.

**CAUTION:** Use drywall anchors when mounting into drywall.

- Use a level to check that the mounting surface is level. Shim the brackets if necessary.
- Attach the installation brackets using the screws provided.

**IMPORTANT:** The front edges of the installation brackets *must* be level and aligned. If mounting to a heavily textured surface, shim the brackets, if needed.

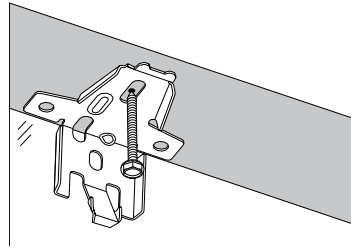
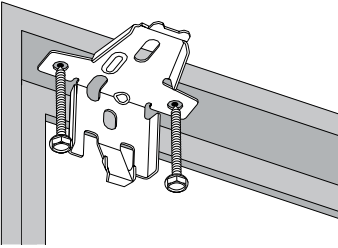

---

Proceed to "STEP 2: Mount the Battery Wand (If Applicable)" on page 10.

---

## Mount the Installation Brackets – Outside Mount

- Center the headrail over the window opening at the desired height. Use a pencil to lightly mark the wall at each end of the headrail.
  - Alternatively, measure the width of the headrail and use that width to mark the headrail end points over the window opening.
- Mark 2" from each end of the headrail.
  - If more than two installation brackets came with your order, space additional bracket(s) evenly between the two end brackets and mark their location. **Allow a minimum of 15" between the brackets on the right-side motor end for the battery wand/rechargeable battery wand.** Mount into wood whenever possible.

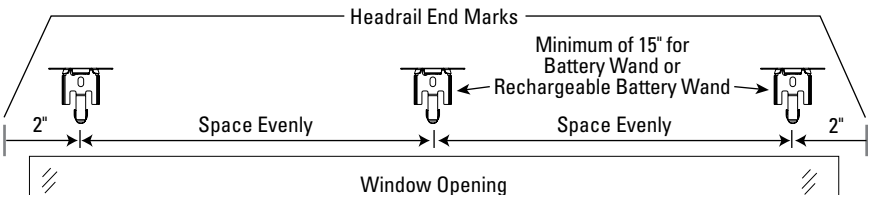

- Center the brackets on your marks, then mark each of the screw holes.
  - A minimum of 1¼" flat vertical surface is required to mount the brackets.
  - The top of the installation brackets or extension brackets should be at the desired shade height. The brackets should be level and aligned.
  - When using extension brackets, mark two screw holes per bracket.

**CAUTION:** The rear of the brackets *must* be flush against a flat mounting surface. *Do not* mount brackets on curved molding.

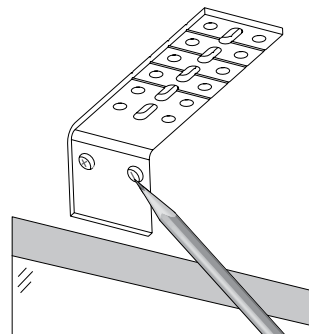
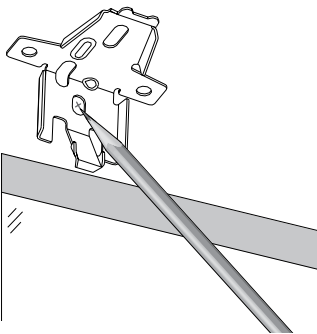

- Drill the screw holes using a 3/32" drill bit.

**CAUTION:** Use drywall anchors when mounting into drywall.

# INSTALLATION

- Attach the installation or extension brackets using the screws provided.

**IMPORTANT:** The front edges of the brackets *must* be level and aligned to each other.

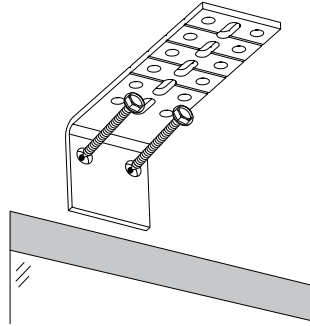
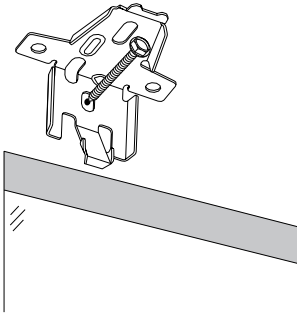

- If using spacer blocks, attach the spacer block/installation bracket assembly to a flat vertical mounting surface with a #6 mounting screw long enough for a secure installation.

- Use one ½" spacer block per installation bracket to provide clearance required for standard battery wand.
- Use two ½" spacer blocks per installation bracket to provide clearance required for rechargeable battery wand.

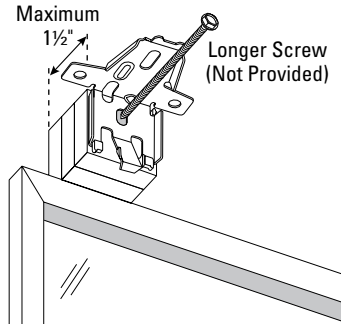
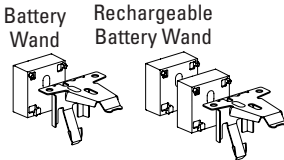

- A maximum of 1½" of spacer blocks per installation bracket is recommended. Spacer blocks and shims may be stacked.
- The top of the spacer blocks should be at the desired shade height.

**CAUTION:** Use drywall anchors when mounting into drywall.

- If using extension brackets, attach an installation bracket to the underside of each extension bracket using the provided screws and speed nuts.

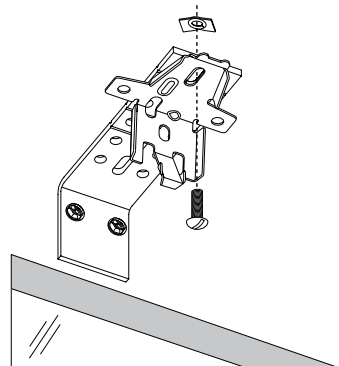

Proceed to "STEP 2: Mount the Battery Wand (If Applicable)" on page 10.

## Mount the Installation Brackets — End Mount

End mount the headrail when conventional mounting techniques will not work — for example, in an arched window opening.

- Position the end mount brackets so that the top of the attached installation brackets are at the ordered height of the shade.

**CAUTION:** Both brackets *must* be installed at the same depth and height.

- Mark both screw holes for each end mount bracket.

- The mounting surface *must* be vertical and flat, not part of an arched curve.

**IMPORTANT:** Add  $\frac{1}{2}$ " to the following minimum mounting depths if a battery wand is used; add  $\frac{3}{4}$ " to the following minimum mounting depths if a rechargeable battery wand is used.

- Minimum mounting depth is  $1\frac{1}{4}$ " for  $\frac{3}{8}$ " and  $\frac{3}{4}$ " pleat sizes and 2" for the  $1\frac{1}{4}$ " pleat size. Minimum mounting depth for a fully recessed end mount is  $2\frac{3}{8}$ " for  $\frac{3}{8}$ " and  $\frac{3}{4}$ " pleat sizes and 3" for the  $1\frac{1}{4}$ " pleat size.

- Drill the screw holes using a  $\frac{3}{32}$ " drill bit.
- Attach the end mount installation brackets using the flat head screws provided.

**CAUTION:** Drywall mounting is not recommended.

**IMPORTANT:** For instructions on installing an arch over a rectangular shade, see the *Installation, Operation, and Care* instructions that came with your arch shade.

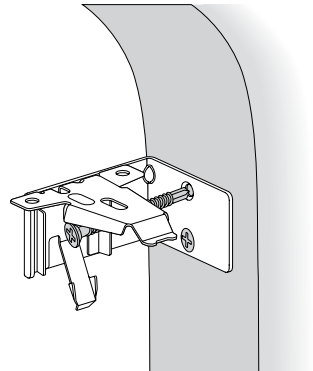
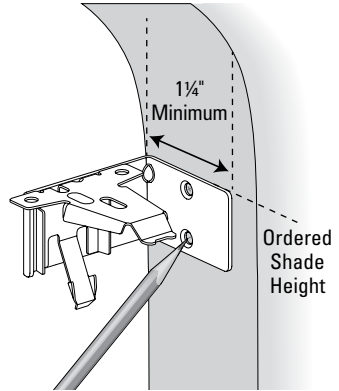

Proceed to "STEP 2: Mount the Battery Wand (If Applicable)" on page 10.

# INSTALLATION

## STEP 2: Mount the Battery Wand (If Applicable)

- Refer to the appropriate page based on your order.
  - For a battery wand, see below.
  - For a headrail-mounted rechargeable battery wand, see page 11.
  - For any other power options, the shade is installed first, see page 13.

### Battery Wand

#### Install the Battery Wand Clips

- Hook the battery wand clip onto the back channel of the headrail.

**IMPORTANT:** Position the clip so that the battery wand will be between installation brackets.

- Rotate the clip down until it snaps into place.

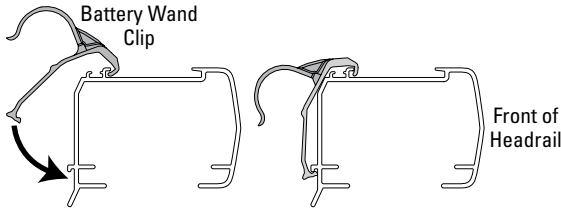

#### Battery Wand Clip

High Mount  
(Standard)

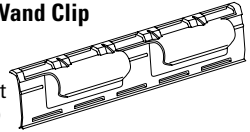

#### Mount the Battery Wand into the Battery Wand Clip

- Align the battery wand with its socket toward the right-side motor end cap.
- Push the battery wand straight up into the battery wand clip until it snaps into place. Check to make sure the battery wand is secure.

**CAUTION:** Be sure the cable does not become pinched by the battery wand clip during installation. Damage or overheating of components could result.

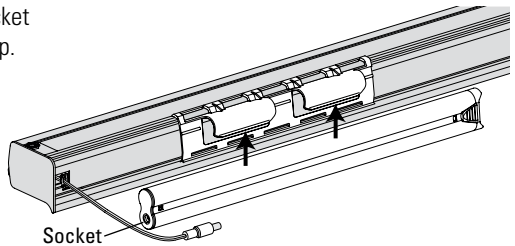

#### Plug the Power Cable into the Battery Wand

- On the back of the headrail, connect the power cable (coming from the shade) into the socket on the battery wand.

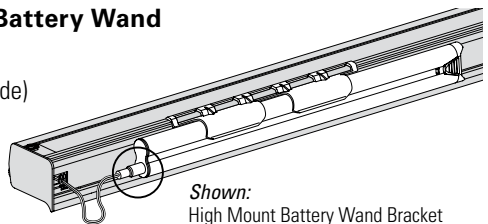

## Solar Charger

For products that use the solar charger option, see the [Solar Charger Installation Guide](#) provided with the order.

Proceed to "STEP 3: Install the Shade" on page 12.

## Headrail-Mounted Rechargeable Battery Wand

### Install the Rechargeable Battery Wand Clips

- Hook the clip onto the back channel of the headrail.

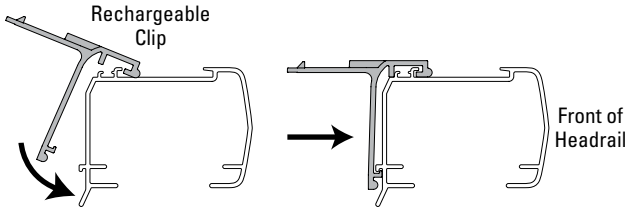

**IMPORTANT:** Position the clip so that the battery wand will be between installation brackets.

- Rotate the clip down and press the middle of the clip until it snaps into place.

### Mount the Rechargeable Battery Mount into the Rechargeable Clips

- From the back of the shade headrail, connect the power cable from the motor side into the socket on the rechargeable battery mount.
- Align the slots in the battery mount with the battery wand clips.
- Push the battery mount onto the battery wand clips until it snaps into place. Check to make sure the battery mount is secure.

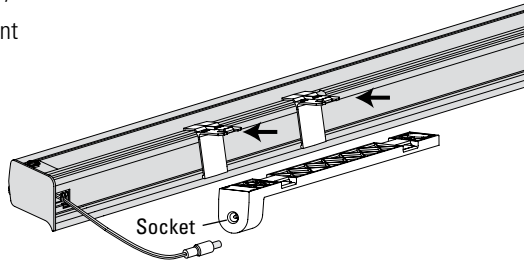

**CAUTION:** Be sure the cable does not become pinched by the battery wand clips during installation. Damage or overheating of components could result.

**NOTE:** Do not install the rechargeable battery wand into the battery mount before installing the shade. See "STEP 4: Connect the Power Source" on page 13 for instructions on inserting the battery wand into the battery mount.

# INSTALLATION

## Solar Charger

For products that use the solar charger option, see the [Solar Charger Installation Guide](#) provided with the order.

Proceed to "STEP 3: Install the Shade" on page 12.

### STEP 3: Install the Shade

#### Mount the Headrail

**CAUTION:** Be sure no cables are pinched by the brackets or headrail during installation; damage or overheating of components could result.

- Fit the front channel on top of the headrail onto the front lip of the installation brackets.
- Push the headrail up and back until it snaps into place.
  - Check that the bottom of the headrail is snapped into the base of each bracket.
  - Check that the front lip of each bracket is in the front channel of the headrail.
- If any brackets are not installed correctly, release the shade and reinstall. See "Removing the Shade" on page 36.

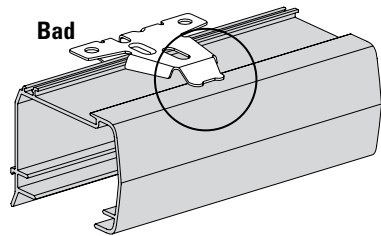
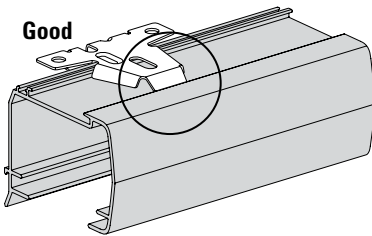
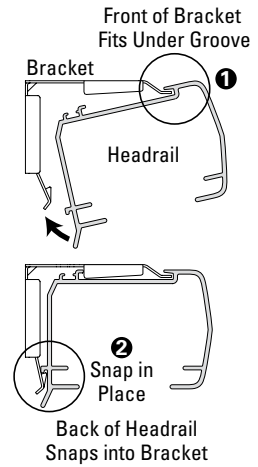

Proceed to "STEP 4: Connect the Power Source" on page 13.

## STEP 4: Connect the Power Source

**NOTE:** When power is connected to the motor, the LED under the control button housing will flash blue to indicate the shade is ready for operation.

- Refer to the appropriate page based on your order.
  - For an optional satellite battery pack, see below.
  - For an optional headrail-mounted rechargeable battery wand, see page 14.
  - For an optional satellite-mounted rechargeable battery wand, see page 15.
  - For an optional 18V DC Power Supply, see page 16.
  - For an optional 18V DC Power Supply with daisy-chain connections, see page 17.
  - For any other Hunter Douglas power options, see the instructions that came with the unit.

### Satellite Battery Pack

#### Mount the Wall Mount Bracket

- Decide where you want to attach the wall mount bracket. A satellite battery pack may be mounted in any orientation.
  - Make sure the provided cable is long enough to connect the satellite battery pack and the shade.
- Mark the screw holes.
- Drill the screw holes using a  $\frac{3}{32}$ " drill bit.
- Remove the backing from the double-sided tape. Press the bracket into place.
- Attach the bracket using the screws provided.

Wall Mount Bracket

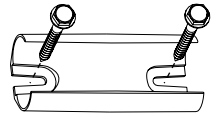

#### Mount the Satellite Battery Pack

- Position the battery wand so the power cable is easily connected to the socket.
- Snap the battery wand into the bracket.

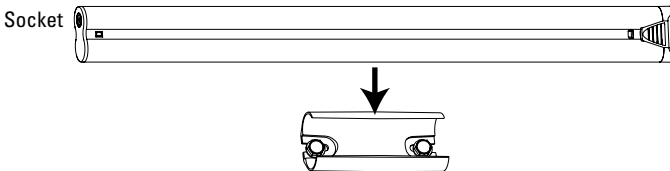

- Install the battery wand cover with the slot aligned to the socket in the battery wand.

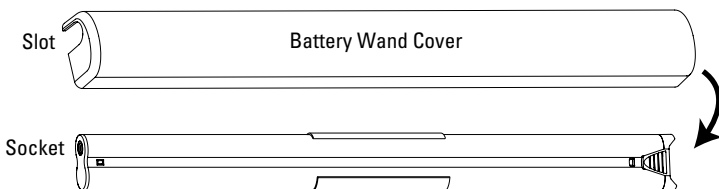

## INSTALLATION

---

- Plug the power cable from the shade into the satellite battery pack cable.
- Plug the other end of the satellite battery pack cable into the socket in the battery wand.

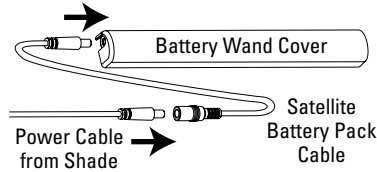

- Secure the satellite battery pack cable using wire retainers (not supplied). If hiding the cable behind the shade, make sure it does not impede the operation of the shade.

---

Proceed to "Testing the Shade" on page 19.

---

### Headrail-Mounted Rechargeable Battery Wand

#### Insert the Rechargeable Battery Wand into the Battery Mount

**NOTE:** The rechargeable battery wand ships fully charged, so it is ready to install out of the package.

- Match the direction of the arrow on the underside of the battery wand with the arrow on the battery mount.

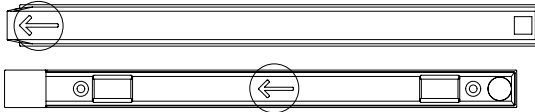

- Insert the nose of the battery wand into the cavity of the battery mount.



- Push the battery wand flush into the mount until the battery snaps into place.

**CAUTION:** Failing to insert wand properly may cause it to fall out of the mount, posing an injury risk and potentially damaging the wand. Additionally, when mounting on a door, closing the door with excess force may cause battery wand to dislodge from the mount, also posing an injury risk and possibly damaging the wand.

- To connect the power for rechargeable battery wands that use the solar charger, see the Installation section of the [Solar Charger Installation Guide](#).

---

Proceed to "Testing the Shade" on page 19.

---

## Satellite-Mounted Rechargeable Battery Wand

### Install the Rechargeable Battery Mount

- Decide where you want to install the rechargeable battery mount. This may be mounted behind the headrail, or in any desired location near the window covering. A satellite battery mount may be installed in any orientation.
  - Make sure the provided cable is long enough to connect the satellite battery mount and the shade.

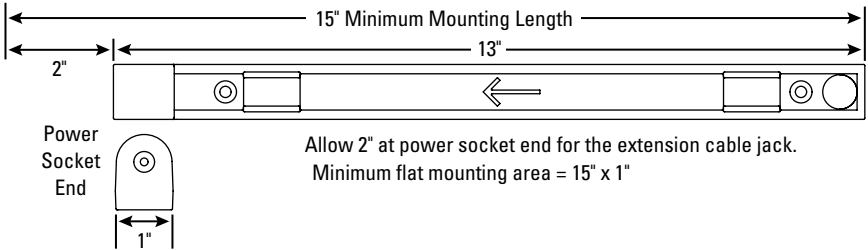

**CAUTION:** The rear of the battery mount *must* be flush against a flat mounting surface. *Do not* install brackets on curved molding.

- Mark the screw holes.
- Drill the screw holes using a  $\frac{3}{32}$ " drill bit.
- Attach the battery mount using the screws provided.

**CAUTION:** Only use the screws provided with the battery mount, designed so that the screws will install flush with the mount. Protrusion of the screws could result in either the battery wand not attaching properly causing a failure to connect, or the wand falling out of the mount. *Do not* over-tighten.

- Connect the power cable from the motor side into the power socket on the rechargeable battery mount.

**NOTE:** With longer extension cables, wire retainers (not supplied) are recommended to secure the cable.

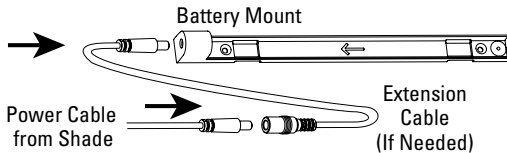

## INSTALLATION

---

### Insert the Battery Wand into the Battery Mount

**NOTE:** The rechargeable battery wand ships fully charged, so it is ready to install out of the package.

- Match the direction of the arrow on the underside of the battery wand with the arrow on the battery mount.

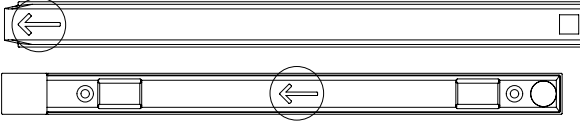

- Insert the nose of the battery wand into the cavity of the battery mount.



- Push the battery wand flush into the mount until the battery snaps into place.

**CAUTION:** Failing to insert wand properly may cause it to fall out of the mount, posing an injury risk and potentially damaging the wand. Additionally, when mounting on a door, closing the door with excess force may cause battery wand to dislodge from the mount, also posing an injury risk and possibly damaging the wand.

- To connect the power for rechargeable battery wands to the solar charger, see the Installation section of the [Solar Charger Installation Guide](#).

Proceed to “Testing the Shade” on page 19.

---

## 18V DC Power Supply

**NOTE:** When power is connected to the motor, a blue LED inside the control button housing will flash to indicate the shade is ready for operation.

- Plug the power cable from the shade motor into the extension cable.
- Plug the other end of the extension cable into the 18V DC power supply.
- Plug the 18V DC power supply into a power source.

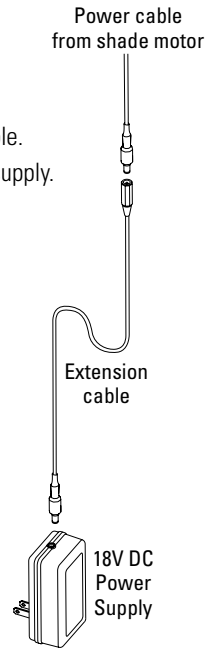

## INSTALLATION

---

### 18V DC Power Supply with Daisy-Chain Connections

**NOTE:** The daisy-chain feature is *only* available with the 18V DC Power Supply option. Refer to this section if you have an 18V Power Supply with daisy-chain connections.

The daisy-chain feature allows up to three PowerView® Gen 3 automated shades to be powered by a single 18V DC Power Supply. However, each shade can operate independently.

- Route the power cables from each shade to the Y Adapter using extension cables (if necessary).
- Plug an extension cable into the Y Adapter and the 18V DC Power Supply. A two-shade configuration is shown below.

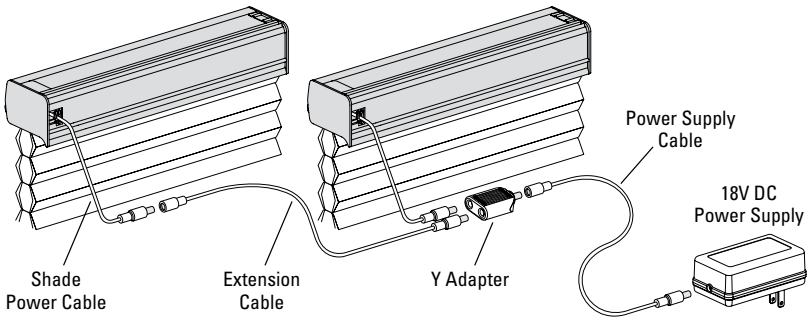

- Plug the 18V DC Power Supply into a standard outlet.
- An additional Y Adapter and two additional extension cables are used for three shades.

---

Proceed to “Testing the Shade” on page 19.

---

## Testing the Shade

Use the control button to test the shade and ensure that the motor and power source are working correctly.

**CAUTION:** When raising the shade for the first time, observe how the fabric stacks. It should stack evenly. Immediately stop the shade if the bottom rail is not level or the shade starts to rub against either window jamb. See “Level the Rail(s)” on page 29.

- Press the control button on the bottom of the right-side end cap to test operation. If the shade does not operate, see “Troubleshooting” on page 30.
  - Press the button to alternately lower, stop, and raise the shade.

The control button can also be used with the PowerView App for advanced shade functions and home access. Open the app, press and hold the control button to see a list of available functions. See “Operating the PowerView® App and Gen 3 Remote” on page 24.

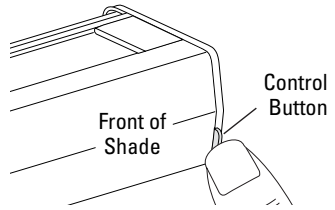

## OPERATION

---

### Operating the PowerView® App and Gen 3 Remote

#### Syncing and Programming Your Remote

- Activate the remote by pulling both plastic tabs from the back battery compartment.
- Download the PowerView® App for your smartphone or tablet at [hdpvapp.com](http://hdpvapp.com).
- Open the PowerView App and follow the steps to set up your new shades and remote.
- Use the PowerView App to program and manage your PowerView Gen 3 remote(s) as accessories.
- For more details, refer to the digital [PowerView Gen 3 Automation Remote Control Guide](#).

#### Basic Operation

- Wake up the remote by picking it up or pressing ■ STOP.
- Press group number(s) 1, 2, 3, 4, 5, and/or 6 to select one or more groups. Selected group numbers light up white on the remote.
- Press selected group number(s) 1, 2, 3, 4, 5 and/or 6 a second time to deselect one or more groups. Deselected group numbers are not lit.

**Bottom Up Shades**

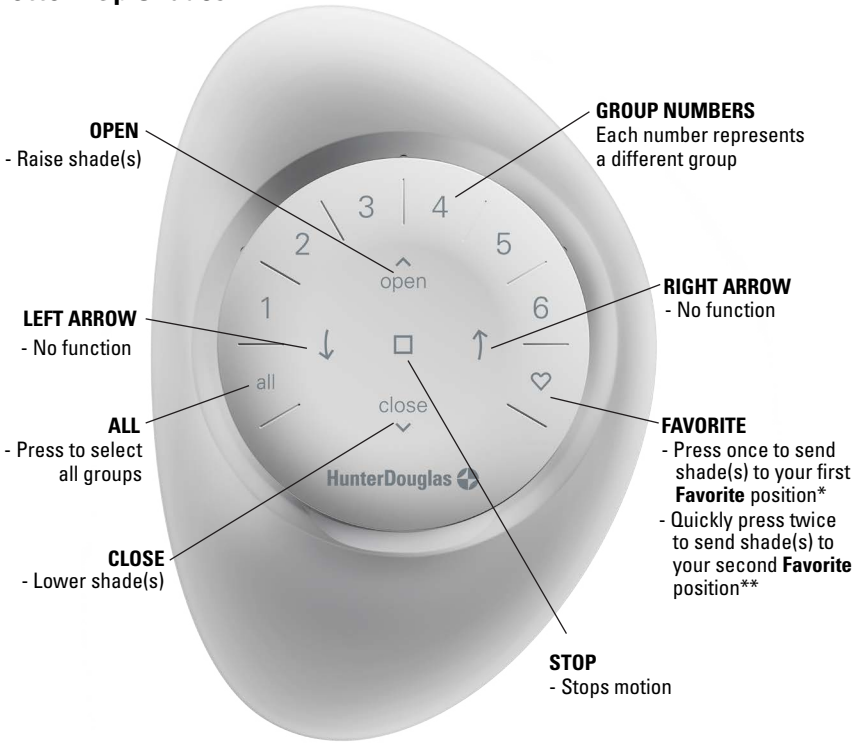

\* The default first **Favorite** position is the front shade(s) at 50% open.

\*\*Both **Favorite** positions can be updated in the PowerView® App > Shade Settings.

**Top-Down Shades**

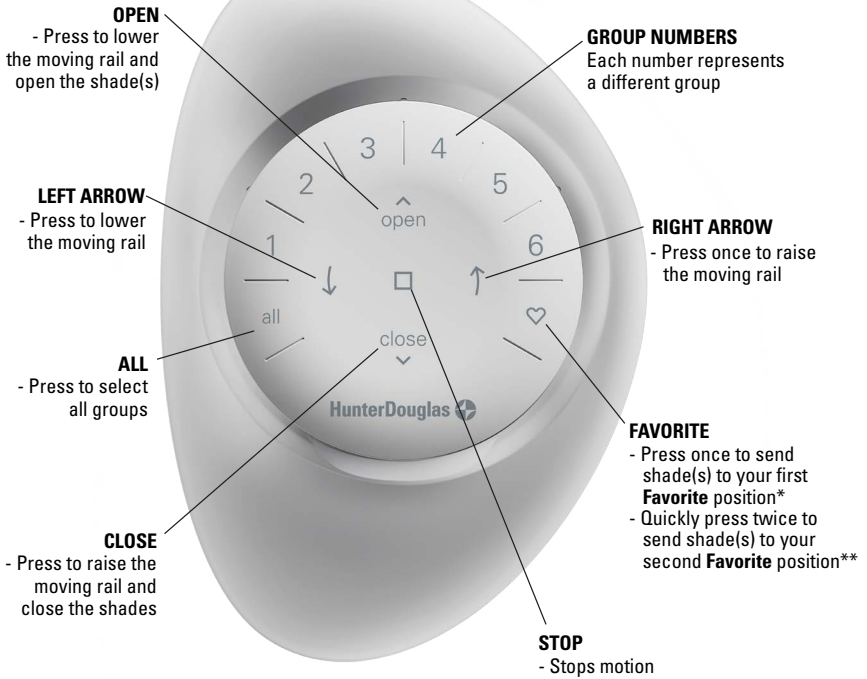

\*The default first **Favorite** position is the shade(s) at 50% open.

\*\*Both **Favorite** positions can be updated in the PowerView® App > Shade Settings.

# OPERATION

---

## **Further Operation and Programming Information**

### **PowerView® App**

The PowerView® App is required to program PowerView Gen 3 shades, remotes, and gateways. The App is compatible with Apple® and Android™ smartphones and tablets. For more information regarding setup and operation using the PowerView App, refer to <https://help.hunterdouglas.com/s/powerview-gen-3-automation>.

### **PowerView® Gen 3 Gateway**

The PowerView® Gen 3 Gateway is used to control shades in larger projects as well as integrate PowerView Gen 3 shades with third-party integration systems. For information regarding programming of PowerView Gen 3 Gateways, refer to the [PowerView Gen 3 Automation Gateway Guide](#).

### **PowerView Gen 3 Remote**

For more information regarding operation and programming of the PowerView Gen 3 Remote, refer to the digital [PowerView Gen 3 Automation Remote Control Guide](#).

## **Resetting the Shade**

### **Calibration Reset**

The calibration reset is used to recalibrate the shade's travel limits. This action is performed in the PowerView App.

- Select Calibrate Shade in the Advanced Options section of the Shade Settings menu in the PowerView App.
- The shade will touch off on end limits, then finish in the closed position. When the shade stops moving, calibration is complete.

### **Resetting Shade Programming**

The PowerView App may be used to modify or reset any shade programming to PowerView Gen 3 Remotes, and Gateways. Shades may be added to or removed from Rooms in the App at any time. If necessary, shades may also be deleted from the PowerView App in the Advanced Options section of the Shade Settings menu.

### **Electronic Limit Adjustments**

Electronic limits are set at the factory and normally do not require readjustment. For window treatments that may need additional adjustment or to set custom limit positions, go to Shade Settings in the PowerView App to adjust limits.

## Level the Rail(s)

- Lift the bottom rail to locate the pockets on the underside of the rail.
  - With the middle rail on Top-Down/Bottom-Up shades, the pockets are on the top side of the rail.
  - See below for the middle rail adjustment on Duolite® shades.
- Gently pull down on the bottom rail (or up on the middle rail) to fully insert the  $\frac{7}{64}$ " EasyAdjust™ key into the pocket. The key is fully inserted when the base of the key abuts to the pocket.
  - Lift up the rail slightly before turning the EasyAdjust key. Turn the key clockwise to raise that side of the rail, or counter-clockwise to lower it.
  - One quarter turn of the key equals approximately  $\frac{1}{4}$ ".

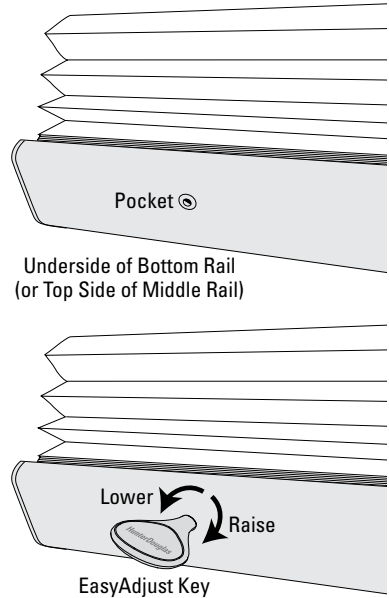

**IMPORTANT:** The EasyAdjust key must be fully inserted to avoid stripping the mechanism. *Do not* pull down on the rail while turning the key.

- If there are more than two pockets, adjust the outer pockets first. Then adjust inner pockets as necessary, to maintain equal tension across the rail. As pocket adjustments are made, it is recommended that the shade be raised and lowered to check that it is level.

# TROUBLESHOOTING

---

## Troubleshooting

If your shade is not operating correctly:

- Review the [digital support guide](#) for your control device.
- Refer to the following troubleshooting procedures for specific solutions for your shade.

If questions remain, please contact Hunter Douglas Consumer Support at [help.hunterdouglas.com](http://help.hunterdouglas.com).

<b>Problem</b>	The shade will not fit into the installation brackets.
<b>Solution</b>	<p>If the shade has a battery wand, check that the wand is not interfering with the installation brackets.</p> <p>Check that the installation brackets are level and aligned. Adjust and/or shim to level, if necessary.</p> <p>Be sure the heads of the mounting screws are flush against the installation bracket.</p> <p>Make sure that the shade fabric is not caught between the installation bracket and the headrail.</p> <p>Check that the headrail is completely inserted into the installation brackets. See "STEP 3: Install the Shade" on page 12.</p>
<b>Problem</b>	The shade does not operate using the control button.
<b>Solution</b>	<p>Unplug the power cable from the motor, then plug it back in. A blue LED inside the control button housing should flash to indicate the motor has power.</p> <p>Check that the batteries in the battery wand, satellite battery pack, or C-size satellite battery wand are correctly inserted and fresh.</p> <p>Check that the power source is securely connected to the power cable and the cables are not pinched or caught in the headrail or installation brackets. If you have the rechargeable battery wand, check to see that the battery wand is correctly positioned in the mount.</p>

<b>Problem</b>	The shade is not responding to the PowerView® Gen 3 remote.
<b>Solution</b>	<p><b>IMPORTANT:</b> A shade will not operate until it is joined to a group, using the PowerView App. See “Basic Operation” on page 24.</p> <p>Check that the correct group number is selected. The LED on that group number will light up. You can also check which group number the shade is joined to on the remote in the PowerView App. You can find this under MORE &gt; ACCESSORIES in the app.</p> <p>Check if the batteries need to be replaced. If the batteries are completely drained, none of the lights will turn on. If batteries are running low, the numbered groups on the remote will begin to illuminate in sequence after each button press, similar to the action seen when syncing a remote. In either case, the batteries need to be replaced. The remote takes two CR2032 batteries.</p>
<b>Problem</b>	The shade is operating slowly or does not raise or lower completely.
<b>Solution</b>	<p>The batteries may be low in the battery wand, satellite battery pack, or C-size battery wand. Replace the batteries.</p> <p>Check that the power source is securely connected to the power cable and the cables are not pinched or caught in the headrail or installation brackets.</p> <p>Check that the fabric stacks up evenly into the headrail. If not, see “Level the Rail(s)” on page 29.</p> <p>The shade may need to be reset. Refer to “Resetting the Shade” on page 28.</p>
<b>Problem</b>	The shade raises or lowers unevenly or the bottom rail is uneven when fully raised.
<b>Solution</b>	<p>Lower the shade <u>completely</u> to allow it to “self-correct” skewing.</p> <p>Check that the headrail and installation brackets are level and aligned. Shim the installation brackets to level the headrail, if necessary.</p>
<b>Problem</b>	The shade limits need to be adjusted - top limit
<b>Solution</b>	See “Electronic Limit Adjustments” on page 28.
<b>Problem</b>	The shade limits need to be adjusted - bottom limit
<b>Solution</b>	See “Electronic Limit Adjustments” on page 28.

# TROUBLESHOOTING

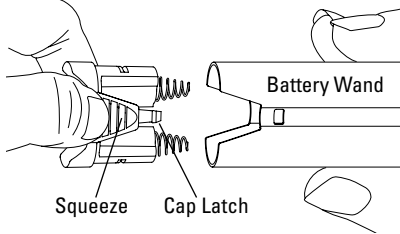
<b>Problem</b>	Batteries in the battery wand need to be replaced.
<b>Solution</b>	<p>Replace the batteries in the battery wand.</p> <p>Squeeze the cap latch to release the cap and remove the cap from the battery wand.</p> <p>Install the batteries according to the instructions on the battery wand label.</p> <p>Press the cap on until it latches.</p> <p><b>NOTE:</b> Hunter Douglas recommends AA alkaline batteries for use with our battery-powered shades. These will provide more than one year of operation, depending on usage. Lithium and rechargeable batteries are not recommended.</p> 
<b>Problem</b>	The battery is charged but the shade does not operate.
<b>Solution</b>	<p>If your rechargeable battery wand is charged but not working, it may be due to its physical location in your window. The rechargeable battery wand can operate in temperatures up to 176°F (80°C). If the temperature in your window exceeds this, its safety feature will shut the battery off temporarily. The battery will turn back on once the temperature lowers into the operable range.</p> <p>If you anticipate the rechargeable battery wand consistently exceeding this temperature limit, please reinstall in a location that avoids direct sunlight.</p>

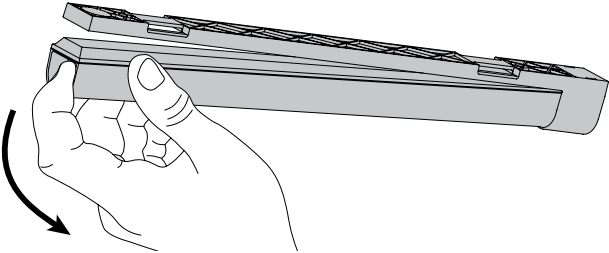
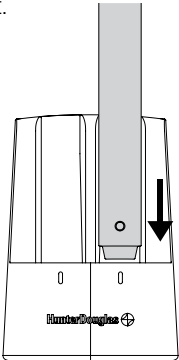
<b>Problem</b>	Rechargeable battery needs recharging.
<b>Solution</b>	<p>There are two methods for charging the rechargeable battery wand — the dual charging station or the single charger.</p> <p><b>CAUTION:</b> The rechargeable battery wand can only be charged with these Hunter Douglas provided charging options. Attempting to charge battery wands with an alternative charger may result in permanent damage.</p> <p><b>Removing the Rechargeable Battery Wand from the Mount</b></p> <ul style="list-style-type: none"> <li>■ To safely remove the rechargeable battery wand from your shade, grasp the end of the battery wand that is furthest away from the power socket.</li> </ul> <p><b>CAUTION:</b> Grasp the wand firmly prior to removal.</p> <ul style="list-style-type: none"> <li>■ Using the indentation on the end of the battery wand, use your index finger to pull the battery out of the mount.</li> </ul> <p><b>NOTE:</b> The mount should remain installed and plugged into the shade cable during this process. You will simply remove the wand from the mount.</p>  <p><b>Recharging Via the Dual Charging Station</b></p> <ul style="list-style-type: none"> <li>■ Plug the dual charging station into a standard AC outlet.</li> <li>■ Insert the nose of the rechargeable battery wand into one of the slots of the dual charging station.</li> <li>■ The battery will firmly snap into place. A red light indicator on the front of the charging station will turn on when the battery wand has been properly inserted and being charged.</li> <li>■ Once the battery has been fully recharged, the red light indicator will turn green. Charging may take up to three hours, depending on your battery level.</li> <li>■ Remove the battery wand from the charger.</li> </ul>  <p>(Continued on next page.)</p>

# TROUBLESHOOTING

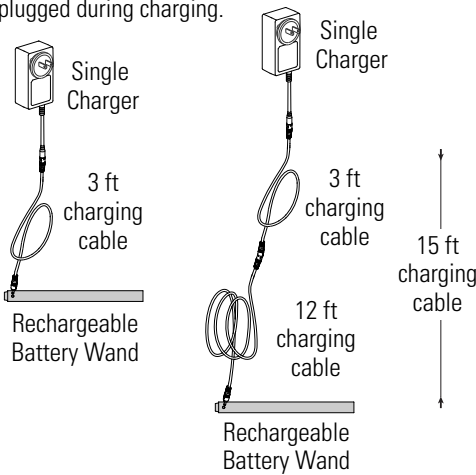
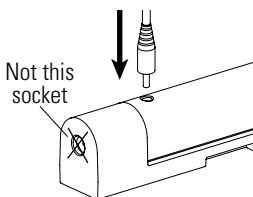
Problem	Rechargeable battery needs recharging (continued)
<p><b>Solution</b></p>	<p><b>Recharging Via the Single Charger</b></p> <p>Remove the rechargeable battery wand from the mount, or insert the single charger cable without removing from the shading.</p> <ul style="list-style-type: none"> <li>■ Attach the plug adapter to the charger.</li> <li>■ Attach the female end of the charging cable to the charger, and the male end to the battery wand. If additional length is required to reach the battery, attach additional charging cables as needed.</li> <li>■ Insert and twist cables together to ensure they do not accidentally become unplugged during charging.</li> </ul> <div style="display: flex; justify-content: space-around; align-items: center;">  </div> <ul style="list-style-type: none"> <li>■ Plug the charger into a standard AC outlet.</li> <li>■ Plug the charging cable into the charging outlet on the rechargeable battery wand. The charging outlet is near the nose of the wand.</li> <li>■ A red light indicator confirms the battery wand is properly inserted and is charging.</li> </ul> <p><b>CAUTION:</b> Do not attempt to plug the charging cable into the battery mount's power socket. Doing so will not only fail to charge the battery wand but could possibly cause damage to both the single charger and the battery mount.</p> <div style="display: flex; justify-content: space-around; align-items: center;">  </div> <ul style="list-style-type: none"> <li>■ Once the battery has been fully recharged, the red light indicator will turn green. Charging may take up to two hours, depending on your battery level.</li> <li>■ Remove the charging cable from the battery wand.</li> </ul> <p>(Continued on next page.)</p>

<b>Problem</b>	Rechargeable battery needs recharging (continued)
<b>Solution</b>	<p><b>Reinserting the Rechargeable Battery Wand into the Mount</b></p> <ul style="list-style-type: none"> <li>■ Match the direction of the arrow on the underside of the battery wand with the arrow on the battery mount.</li> <li>■ Insert the nose of the battery wand into the cavity of the battery mount.</li> <li>■ Push the battery wand flush into the mount until the battery snaps into place</li> </ul>
<b>Problem</b>	My solar charged battery is low in power or drained.
<b>Solution</b>	<p>For best performance, the Solar Charger must be installed as recommended. See the Optimal Solar Charger Placement section of the <a href="#">Solar Charger Installation Guide</a>.</p> <p>The rechargeable battery should be fully charged before installation of the solar charger. Some installations may also require occasional manual battery recharging, depending on the solar charger's access to sunlight and shade use. For instructions on manually recharging your rechargeable battery, see the Troubleshooting section on "Rechargeable battery wand needs recharging."</p>

## CARE

---

### Removing the Shade

- Lower the shade approximately 4".
- While holding the headrail, push back on the bottom tab of the installation bracket with a flat blade screwdriver to release the bottom edge of the headrail.
- After releasing the bottom edge, roll the back of the headrail down and out from the bracket.

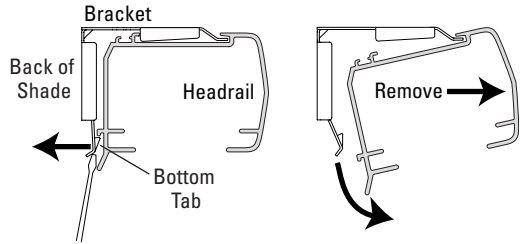

### Cleaning Procedures

Hunter Douglas Duette® and Applause® Honeycomb Shades are made of anti-static, dust-resistant fabric which repels dirt and dust. For most honeycomb fabrics, the following cleaning options are available.

#### Dusting

- Regular light dusting with a feather duster is all the cleaning needed in most circumstances.

#### Vacuuming

**CAUTION:** *Do not* vacuum Elan® or Elan® Metallic fabrics.

- For deeper cleaning, vacuum gently with a brush attachment.

#### Compressed Air/Hair Dryer (Cool Setting)

- Use compressed air or a hair-dryer on a cool setting to blow dust and dirt off shades.

#### Spot-Cleaning

**CAUTION:** *Do not* spot-clean Alexa™, Commercial, Elan, Elan Metallic, Esprit™, India Silk™, Leela™, Macon™, Thea™, or Batiste fabrics.

- Prepare a solution of warm water and a mild detergent.
- Dampen a clean cloth in the solution and wring it out.
- Dab the spot with the dampened cloth until it is removed. Do not rub the fabric.
- Allow the shade to dry in the completely lowered (or closed) position.

### **Ultrasonic Cleaning**

**CAUTION:** *Do not* ultrasonically clean Commercial, Batiste 1¼" Semi-Sheer, ClearView™ Sheer fabrics, or any room-darkening fabric.

- Specify that a mild detergent solution be used.

**IMPORTANT:** Never immerse the headrail into the solution.

- Dry the shade completely in the lowered (or closed) position.

### **Injection/Extraction Cleaning**

This type of professional cleaning injects a cleaning solution into the fabric and extracts the dirty solution in the same motion.

- Use only the dry method of injection/extraction for Elan and Elan Metallic fabrics.
- If using injection/extraction for Alexa, Batiste Bamboo or Thea fabrics, specify water only; no chemicals.
- Leave shades in closed position (stacked) for at least 15 minutes after cleaning.

### **Headrail Cleaning**

**CAUTION:** Never use abrasive cleaning methods or harsh chemicals.

- Dampen a soft, clean cloth in warm water and wring it out.
- Gently wipe the headrail to remove dirt and dust.

# DECLARATIONS

---

## ***FCC Compliance Statement***

**NOTE:** This equipment has been tested and found to comply with the limits for a Class B digital device, pursuant to Part 15 of the FCC Rules. These limits are designed to provide reasonable protection against harmful interference in a residential installation. This equipment generates, uses and can radiate radio frequency energy and, if not installed and used in accordance with the instructions, may cause harmful interference to radio communications. However, there is no guarantee that interference will not occur in a particular installation. If this equipment does cause harmful interference to radio or television reception, which can be determined by turning the equipment off and on, the user is encouraged to try to correct the interference by one or more of the following measures:

- Reorient or relocate the receiving antenna.
- Connect the equipment into an outlet on a circuit different from that to which the receiver is connected.
- Increase the separation between the equipment and receiver.
- Consult the dealer or an experienced radio/tv technician for help.

**NOTE:** Changes or modifications not expressly approved by the manufacturer responsible for compliance could void the user's authority to operate the equipment.

Responsible Party:

Hunter Douglas Window Fashions, Inc.  
One Duette Way  
Broomfield, CO 80020  
USA

[help.hunterdouglas.com](http://help.hunterdouglas.com)

## ***ISED Canada Compliance Statement***

This device contains licence-exempt transmitter(s)/receiver(s) that comply with Innovation, Science and Economic Development Canada's licence exempt RSS(s).

This Class B digital apparatus complies with Canadian ICES-003.

Operation is subject to the following two conditions: (1) This device may not cause interference. (2) This device must accept any interference, including interference that may cause undesired operation of the device.

Cet appareil contient des émetteurs/récepteurs sans licence qui sont conformes aux RSS sans licence d'Innovation, Sciences et Développement économique Canada.

Cet appareil numérique de la classe B est conforme à la norme NMB-003 du Canada.

Le présent appareil est conforme aux CNR d'ISDE Canada applicables aux appareils radio exempts de licence. L'exploitation est autorisée aux deux conditions suivantes : (1) l'appareil ne doit pas produire de brouillage, et (2) l'appareil doit accepter tout brouillage radioélectrique subi, même si le brouillage est susceptible d'en compromettre le fonctionnement.

## ***CE and UKCA Compliance Statement***

Hunter Douglas Window Fashions, One Duette Way, Broomfield, CO 80020, USA

Hunter Douglas hereby declares that the PV48 is in compliance with the essential requirements and other relevant provisions of Electromagnetic Compatibility (EMC) Directive 2014/30/EU and Radio Equipment Directive (RED) 2014/53/EU. A copy of the DoC can be obtained upon request at [help.hunterdouglas.com](http://help.hunterdouglas.com).



# ⚠️ WARNING/ ADVERTENCIA

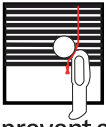

Window Blind Cord  
Can **STRANGLE**  
Your Child. To

prevent strangulation, purchase  
cordless products or products  
with inaccessible cords.

La cuerda de la persiana puede  
**ESTRANGULAR** a su niño. Para  
evitar el estrangulamiento, com-  
pre alternativas cuerda o prod-  
uctos con cuerdas inaccesibles.

## ⚠️ WARNING

STRANGULATION HAZARD – Young  
children can be strangled by cords.  
Immediately remove this product if a cord  
longer than 22 cm or a loop exceeding  
44 cm around becomes accessible.

## ⚠️ MISE EN GARDE

RISQUE D'ÉTRANGLEMENT – Les  
enfants en bas âge peuvent s'étrangler  
avec des cordes. Enlevez immédiate-  
ment ce produit si une corde mesurant  
plus de 22 cm devient accessible ou si  
le contour d'une boucle de plus de 44  
cm devient accessible.

## LIFETIME GUARANTEE

The Hunter Douglas® Lifetime Guarantee is an expression of our desire to provide a thoroughly satisfying experience when selecting, purchasing and living with your window fashion products. If you are not thoroughly satisfied, simply contact Hunter Douglas at **(800) 789-0331** or visit [hunterdouglas.com](http://hunterdouglas.com). In support of this policy of consumer satisfaction, we offer our Lifetime Limited Warranty as described below.

### COVERED

#### BY A LIFETIME LIMITED WARRANTY

- Hunter Douglas window fashion products are covered for defects in materials, workmanship or failure to operate for as long as the original retail purchaser owns the product (unless shorter periods are provided below).
- All internal mechanisms.
- Components and brackets.
- Fabric delamination.
- Operational cords for a full 7 years from the date of purchase.
- Repairs and/or replacements will be made with like or similar parts or products.
- Hunter Douglas motorization components are covered for 5 years from the date of purchase.

Hunter Douglas (or its licensed fabricator/distributor) will repair or replace the window fashion product or components found to be defective.

### NOT COVERED

#### BY A LIFETIME LIMITED WARRANTY

- Any conditions caused by normal wear and tear.
- Abuse, accidents, misuse or alterations to the product.
- Exposure to the elements (sun damage, wind, water/moisture) and discoloration or fading over time.
- Failure to follow our instructions with respect to measurement, proper installation, cleaning or maintenance.
- Shipping charges, cost of removal and reinstallation.

### TO OBTAIN WARRANTY SERVICE

1. Contact your original dealer (place of purchase) for warranty assistance.
2. Visit [hunterdouglas.com](http://hunterdouglas.com) for additional warranty information, frequently asked questions and access to service locations.
3. Contact Hunter Douglas at **(800) 789-0331** for technical support, certain parts free of charge, for assistance in obtaining warranty service or for further explanation of our warranty.

**NOTE:** In no event shall Hunter Douglas or its licensed fabricators/distributors be liable or responsible for incidental or consequential damages or for any other indirect damage, loss, cost or expense. Some states do not allow the exclusion or limitation of incidental or consequential damages, so the above exclusion or limitation may not apply to you. This warranty gives you specific legal rights, and you may also have other rights which vary from state to state.

Different warranty periods and terms apply for commercial products and applications.