

Sonesse 50 RTS Motors

Wiring Options

PLUG-IN

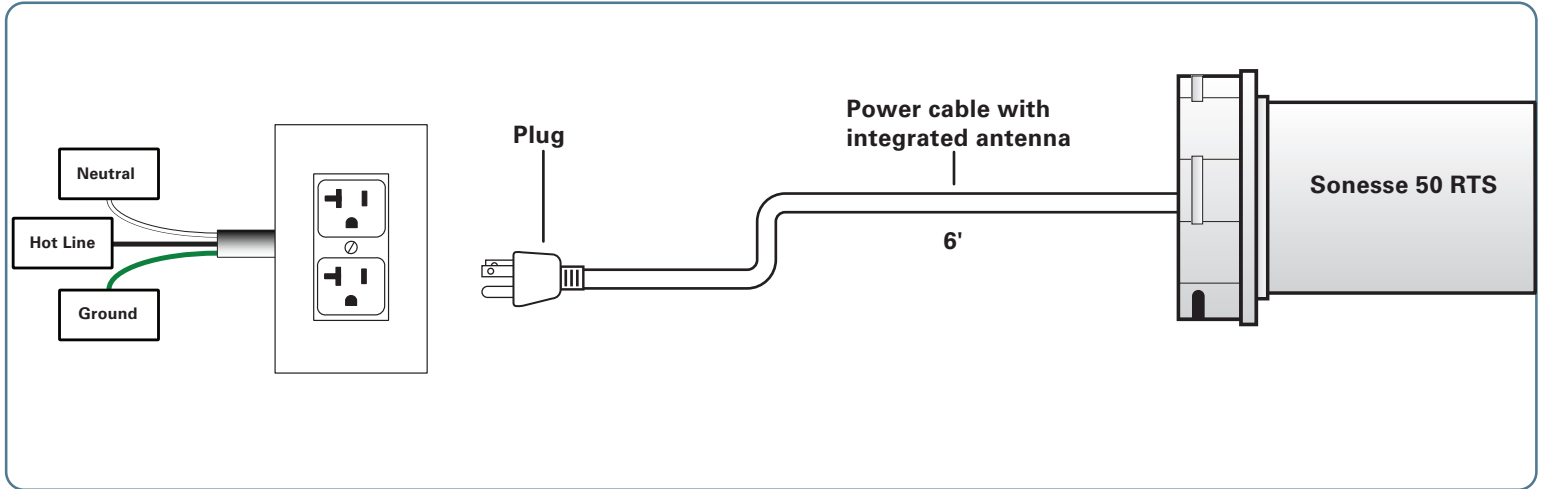

HARDWIRED TO JUNCTION BOX (Electrician Required)

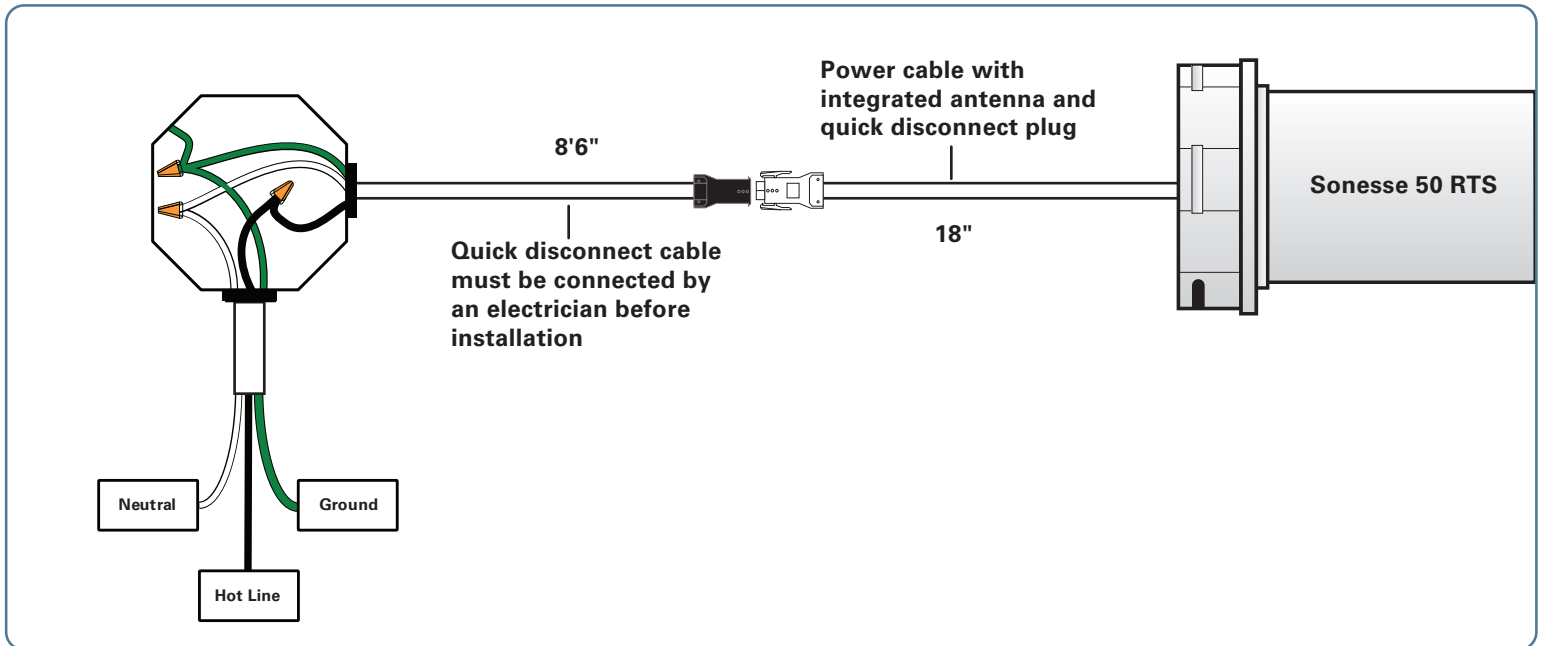

FOR OPTIMAL PERFORMANCE, THE POWER CABLE/ANTENNA MUST BE AT LEAST 18" LONG AND MUST NOT COME IN CONTACT WITH METAL.

For additional information please email HDHsupport@hunterdouglas.com or call 800.229.5300.